

USER GUIDE

SCC-RLY01 Relay Module

The SCC-RLY01 contains one single-pole double-throw (SPDT) nonlatching relay capable of switching 5 A at 30 VDC when using an SC-2345 or SC-2350, or 250 VAC when using an SCC-68. Any single E/M Series DAQ device digital input/output (P0) line 0 to 7 can control the SCC-RLY01.

The SCC-RLY01 uses positive logic. A digital high sets the relay, and a digital low resets it. In the set state, the common (COM) contact is connected to the normally open (NO) contact. In the reset state, the common (COM) contact is connected to the normally closed (NC) contact.

Conventions

The following conventions are used in this guide:

<>

Angle brackets that contain numbers separated by an ellipsis represent a range of values associated with a bit or signal name—for example, P0 <3..0>.

»

The » symbol leads you through nested menu items and dialog box options to a final action. The sequence **File»Page Setup»Options** directs you to pull down the **File** menu, select the **Page Setup** item, and select **Options** from the last dialog box.



This icon denotes a note, which alerts you to important information.



This icon denotes a caution, which advises you of precautions to take to avoid injury, data loss, or a system crash. When this symbol is marked on the product, refer to the *Read Me First: Safety and Radio-Frequency Interference* document, shipped with the product, for precautions to take.



When symbol is marked on a product, it denotes a warning advising you to take precautions to avoid electrical shock.



When symbol is marked on a product, it denotes a component that may be hot. Touching this component may result in bodily injury.

bold	Bold text denotes items that you must select or click in the software, such as menu items and dialog box options. Bold text also denotes parameter names.
<i>italic</i>	Italic text denotes variables, emphasis, a cross-reference, or an introduction to a key concept. Italic text also denotes text that is a placeholder for a word or value that you must supply.
monospace	Text in this font denotes text or characters that you should enter from the keyboard, sections of code, programming examples, and syntax examples. This font is also used for the proper names of disk drives, paths, directories, programs, subprograms, subroutines, device names, functions, operations, variables, filenames, and extensions.
SC-2345	SC-2345 refers to both the SC-2345 connector block and SC-2345 with configurable connectors.
SCC	SCC refers to any SCC Series signal-conditioning module.

What You Need to Get Started

To set up and use the SCC-RLY01, you need the following items:

- Hardware
 - SCC-68 or SC-2345 with one of the following:
 - SCC-PWR01
 - SCC-PWR02 and the PS01 power supply
 - SCC-PWR03 (requires a 7 to 42 VDC power supply, not included)
 - One or more SCC-RLY01 modules
 - 68-pin E/M Series DAQ device
 - 68-pin cable
 - Quick Reference Label
- Software
 - The latest version of NI-DAQmx
- Documentation
 - *SCC-RLY01 Relay Module User Guide*
 - *SC-2345/2350 User Manual* or *SCC-68 User Guide*
 - *SCC Quick Start Guide*
 - *Read Me First: Safety and Radio-Frequency Interference*

- Documentation for your hardware
- Documentation for your software

 Tools

- 1/8 in. flathead screwdriver
- Numbers 1 and 2 Phillips screwdrivers
- Wire insulation stripper

You can download NI documents from ni.com/manuals. To download the latest version of NI-DAQ, click **Download Software** at ni.com.



Note Configuring the SCC system using Measurement & Automation Explorer (MAX) is not supported on the Macintosh operating system.

Device Specific Information



Note For general SCC module installation and signal connection information, and information about the SCC-68 or SC-2345 carrier, refer to the *SCC Quick Start Guide*, available for download at ni.com/manuals.

Installing the Module



Caution Refer to the *Read Me First: Safety and Radio-Frequency Interference* document before removing equipment covers or connecting/disconnecting any signal wires.

Plug the SCC-RLY01 into any DIO socket J(X+9), where X is 0 to 7, on the SC-2345, or into any of the four slots that correspond to P0.0 to P0.3 on the SCC-68.

Connecting the Input Signals



Note The signal names have changed. Refer to ni.com/info and enter `rdntntg` to confirm the signal names.

Each screw terminal is labeled by pin number <1..3>. Pin 1 is the NC terminal, pin 2 is the COM terminal, and pin 3 is the NO terminal.

The SCC-RLY01 contains one SPDT relay controlled by the digital line of an E/M Series DAQ device P0. line X. The value of X is determined by the number of the DIO socket, J(X+9) on the SC-2345 or SCC Mod (X + 1) on the SCC-68, where you plug in the SCC-RLY01. Figure 1 shows a circuit diagram of the SCC-RLY01.

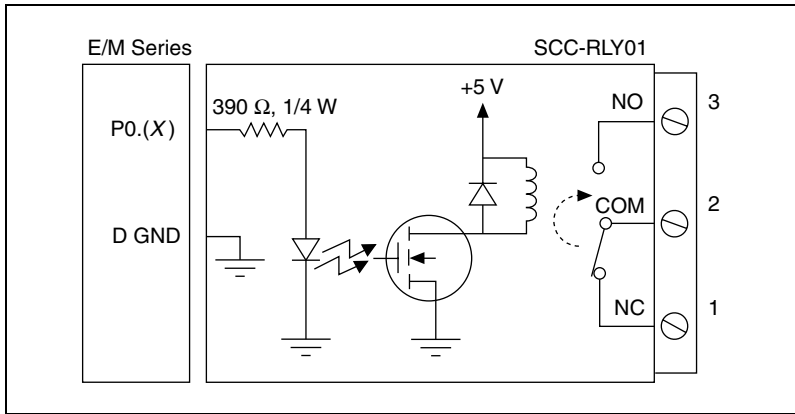

Figure 1. SCC-RLY01 Circuit Diagram



Caution When connecting signals >60 VDC to the SCC-RLY01 module in the SCC-68, you must use the high-voltage backshell. Figure 2 shows the high-voltage backshell.

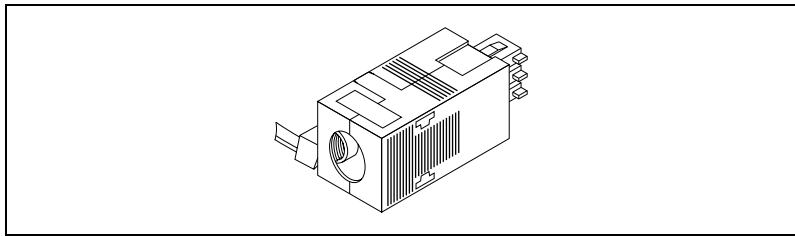

Figure 2. High-Voltage Backshell

For information about how to configure the SCC-RLY01 module with NI-DAQmx, refer to the *SCC Quick Start Guide*.

Specifications

These ratings are typical at 25 °C unless otherwise stated.

Electrical

Contact type.....SPDT (Form C), nonlatching

Nominal switching capacity

SCC-68	5 A at 250 VAC
	5 A at 30 VDC
SC-2345	5 A at 30 VAC
	5 A at 30 VDC



Caution The SCC-RLY01 module is derated to 30 V maximum switching voltage in the SC-2345 carrier regardless of any other voltage markings found on the SCC-RLY01 module case.

Signal bandwidth..... DC to 400 Hz

Contact resistance 30 mΩ max

Switching time

 Operate time (NC to NO)..... 5 ms (10 ms max)

 Release time (NO to NC)..... 4 ms (5 ms max)¹

Maximum operating speed..... 30 cps at rated load

Contact lifetime 5×10^7 operations at 180 cpm (minimum)

Power Requirement

Digital power..... 300 mW max

+5 V 60 mA max

Physical

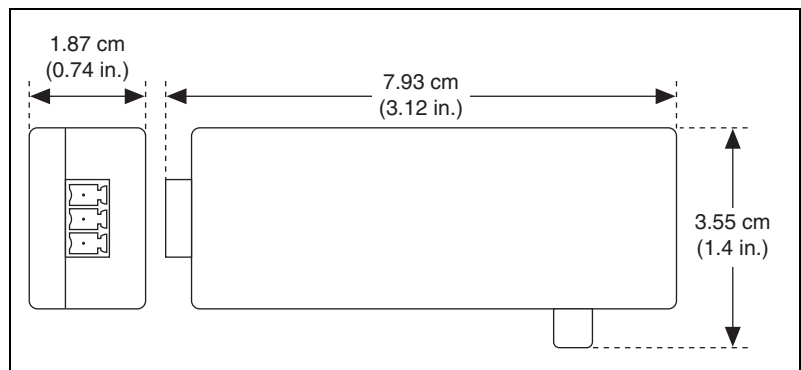

Figure 3. SCC-RLY01 Dimensions

Weight..... 37 g (1.3 oz)

¹ Excluding contact bounce time

I/O connectors.....	One 20-pin right-angle male connector One 3-pin screw-terminal block
Field-wiring diameter	28 to 16 AWG

Maximum Working Voltage

Maximum working voltage refers to the signal voltage plus the common-mode voltage.

When used with an SCC-2345

Channel-to-earth (inputs).....	± 60 VDC, Measurement Category I
--------------------------------	--------------------------------------



Caution Do not use for connection to signals in Measurement Category II, III, or IV. Do not connect to MAINS.

When used with an SCC-68

Channel-to-earth (inputs).....	± 300 VDC, Measurement Category II ¹
--------------------------------	---



Caution Do not use for connection to signals in Measurement Category III, or IV.

Isolation Voltage

Channel-to-channel, channel-to-earth isolation

Continuous.....	60 VDC, Measurement Category I
Withstand.....	2300 V _{rms} verified by a 5 s dielectric withstand type test

Environmental

Operating temperature	0 to 50 °C
Storage temperature	-20 to 65 °C
Humidity	10 to 90% RH, noncondensing
Maximum altitude.....	2,000 m
Pollution Degree (indoor use only)	2

¹ For voltages >60 VDC, you must use the high-voltage backshell.

Safety

This product meets the requirements of the following standards of safety for electrical equipment for measurement, control, and laboratory use:

- IEC 61010-1, EN 61010-1
- UL 61010-1, CSA 61010-1



Note For UL and other safety certifications, refer to the product label or the *Online Product Certification* section.

Electromagnetic Compatibility

This product meets the requirements of the following EMC standards for electrical equipment for measurement, control, and laboratory use:

- EN 61326 (IEC 61326): Class A emissions; Basic immunity
- EN 55011 (CISPR 11): Group 1, Class A emissions
- AS/NZS CISPR 11: Group 1, Class A emissions
- FCC 47 CFR Part 15B: Class A emissions
- ICES-001: Class A emissions



Note For the standards applied to assess the EMC of this product, refer to the *Online Product Certification* section.



Note For EMC compliance, operate this product according to the documentation.



Note For EMC compliance, operate this device with shielded cables.

CE Compliance

This product meets the essential requirements of applicable European Directives as follows:

- 2006/95/EC; Low-Voltage Directive (safety)
- 2004/108/EC; Electromagnetic Compatibility Directive (EMC)

Online Product Certification

Refer to the product Declaration of Conformity (DoC) for additional regulatory compliance information. To obtain product certifications and the DoC for this product, visit ni.com/certification, search by model number or product line, and click the appropriate link in the Certification column.

Environmental Management

NI is committed to designing and manufacturing products in an environmentally responsible manner. NI recognizes that eliminating certain hazardous substances from our products is beneficial to the environment and to NI customers.

For additional environmental information, refer to the *NI and the Environment* Web page at ni.com/environment. This page contains the environmental regulations and directives with which NI complies, as well as other environmental information not included in this document.

Waste Electrical and Electronic Equipment (WEEE)



EU Customers At the end of the life cycle, all products *must* be sent to a WEEE recycling center. For more information about WEEE recycling centers and National Instruments WEEE initiatives, visit ni.com/environment/weee.

电子信息产品污染控制管理办法（中国 RoHS）



中国客户 National Instruments 符合中国电子信息产品中限制使用某些有害物质指令 (RoHS)。关于 National Instruments 中国 RoHS 合规性信息，请登录 ni.com/environment/rohs_china。(For information about China RoHS compliance, go to ni.com/environment/rohs_china.)

SCC-RLY01 Module Pin Assignments

Figure 4 shows the I/O connector pins on the bottom of the module.

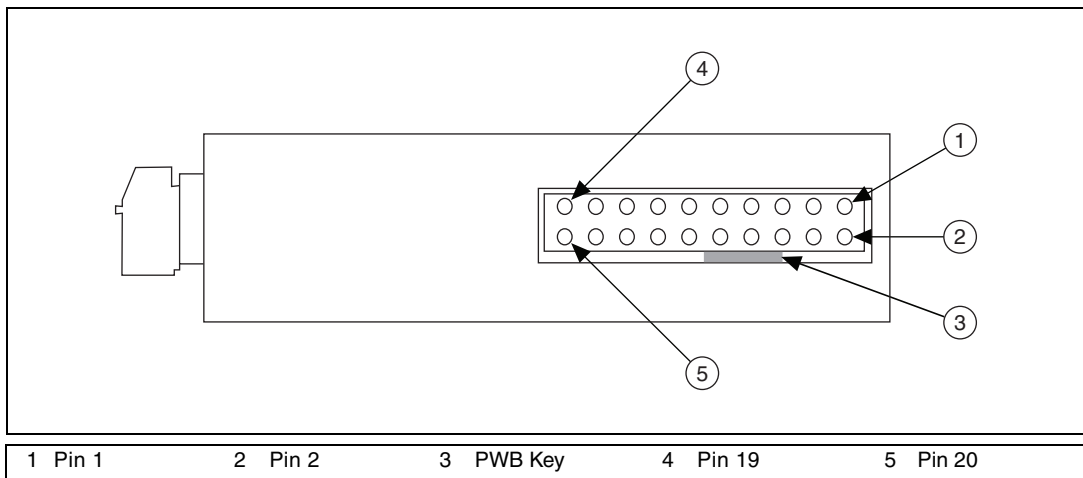

Figure 4. SCC Module Bottom View

Table 1 lists the signal connection corresponding to each pin. GND is the reference for the +5 V supply.

Table 1. SCC-RLY01 Pin Signal Connections

Pin Number	Signal
1	—
2	—
3	—
4	—
5	—
6	—
7	P0.(X)
8	—
9	+5 V
10	GND
11	—
12	—
13	—
14	—
15	—
16	—
17	—
18	—
19	—
20	—

National Instruments, NI, ni.com, and LabVIEW are trademarks of National Instruments Corporation. Refer to the *Terms of Use* section on ni.com/legal for more information about National Instruments trademarks. Other product and company names mentioned herein are trademarks or trade names of their respective companies. For patents covering National Instruments products/technology, refer to the appropriate location: **Help»Patents** in your software, the `patents.txt` file on your media, or the *National Instruments Patent Notice* at ni.com/patents.